

GEN II YOKE STYLE MAN BASKET

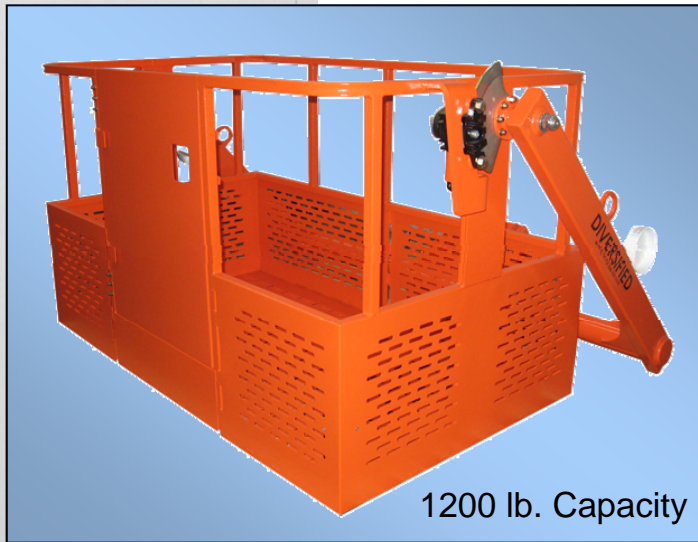
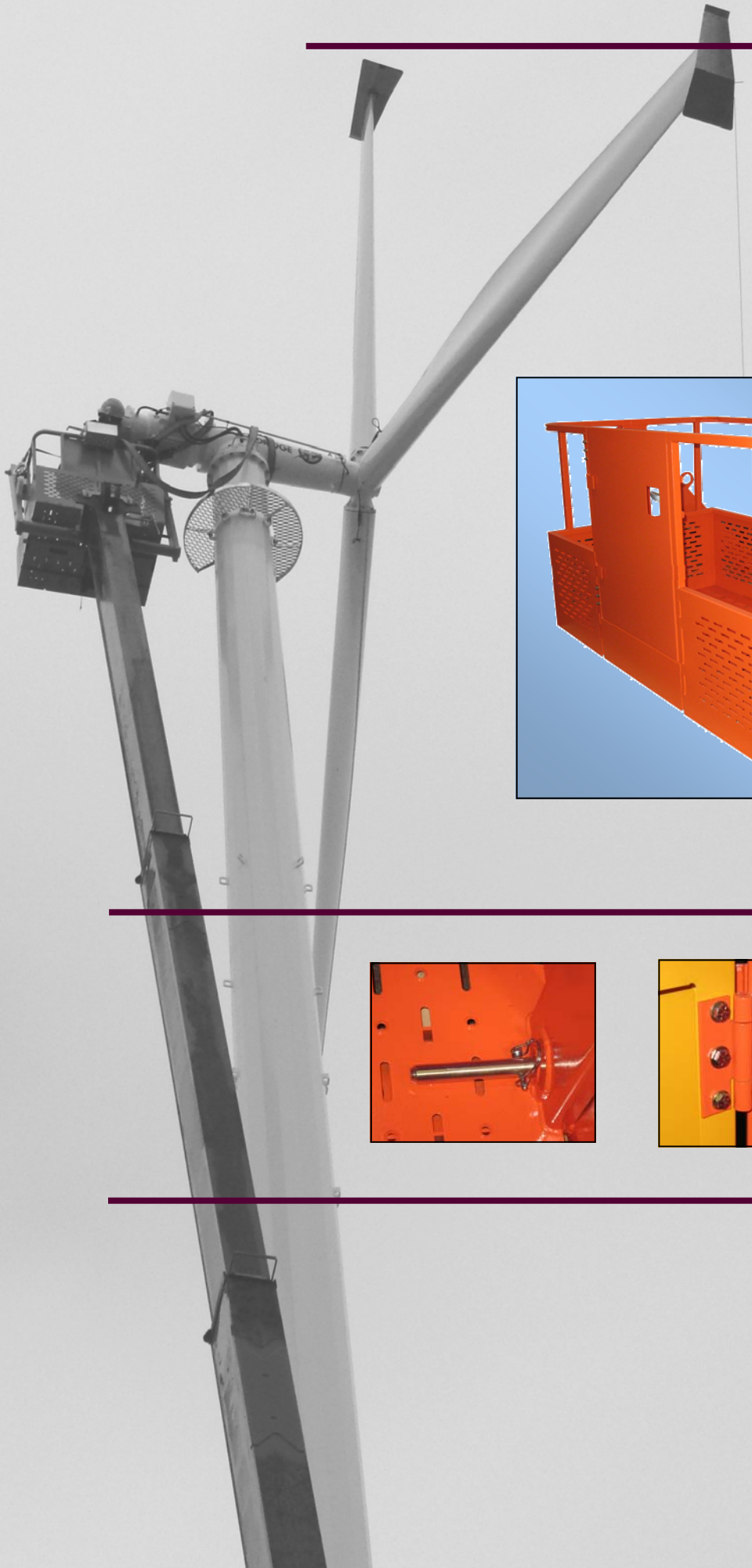

DIVERSIFIED

P R O D U C T S

(254) 757-1177

www.diversifiedproduct.com

The next generation basket designed by engineers after many years of input from operators and field crews

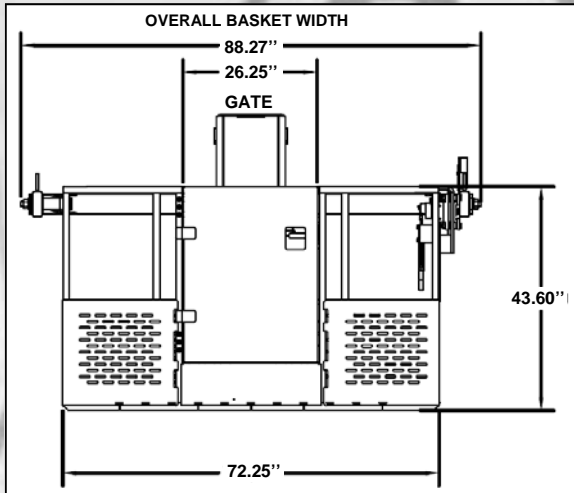

- Full-sized floor provides more space for men and materials - 21 square feet

Features and Benefits:

- **Steel construction to meet the rigors of contractors and utility applications**
- **Fabricated with laser produced parts, keyed together, then welded into place by certified welders**
- **Entire assembly designed utilizing solid modeling and Finite Element Analysis**
- **Meets or exceeds industry standards**

DIVERSIFIED
P R O D U C T S

1001 Webster Avenue
Waco, Texas 76706
254-757-1177 phone
noahg@diversifiedproduct.com
www.diversifiedproduct.com
© 2009 Diversified Products

Photos and diagrams are for promotional purposes only.

Product design and specifications may change without notice or obligation.

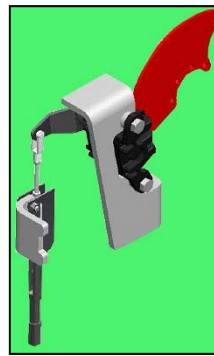

BRAKE

- High capacity disc brake
- Heavy duty linkage
- Plated brake disc

FLOOR

- Slots in the floor to drain water
- Upset holes for skid resistance
- 42" x 72"

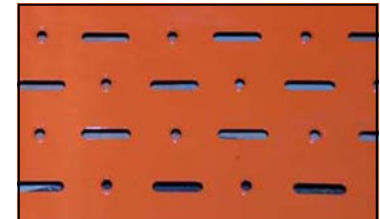

ENTRANCE

- Gate swings inward to provide security
- Heavy duty hinges with stainless steel pins provide long life
- Basket entrance has reinforcement for rugged applications
- Gate clearance to the floor provides added storage space

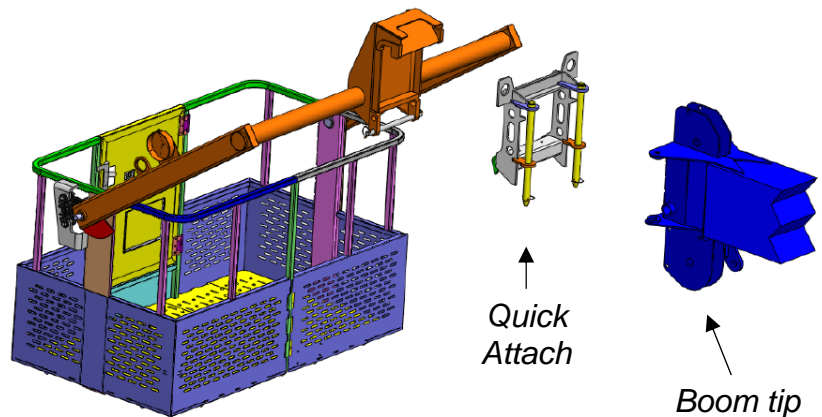

QUICK ATTACH MOUNTING

- Ease of installation on a crane tip
- Basket universal mounting permits installation on multiple cranes

Contact Diversified for all your man basket needs. Yoke style 4', 6', single man, rotating and special requirements.

Diversified Products provides customer-focused solutions to make you more efficient, productive and safe. We manufacture innovative products driven by input straight from the field.

PRODUCT CONCEPT

PRODUCT ENGINEERING

PRODUCT FABRICATION