

GEN II YOKE STYLE SINGLE MAN BASKET

350 lb. Capacity

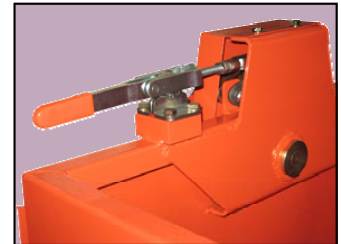

DIVERSIFIED

P R O D U C T S

(254) 757-1177

www.diversifiedproduct.com

The next generation basket designed by engineers after many years of input from operators and field crews

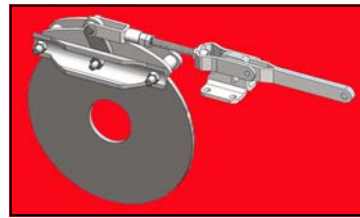

BRAKE

- High capacity disc brake
- Heavy duty linkage

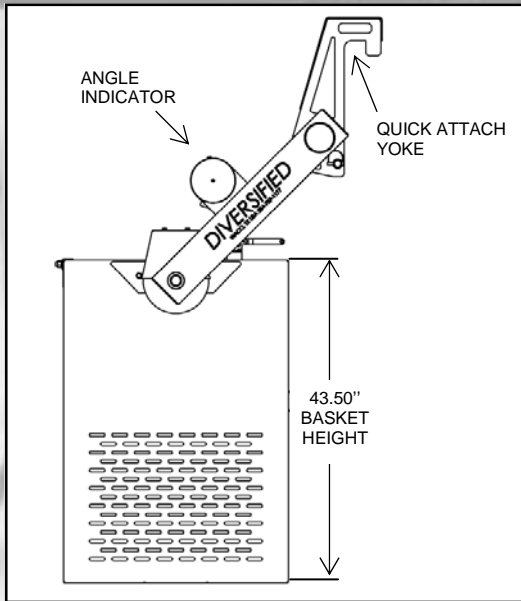

ENTRANCE

- Bar at top of basket pivots out of the way to enter.

FLOOR

- Slots in the floor to drain water
- Upset holes for skid resistance

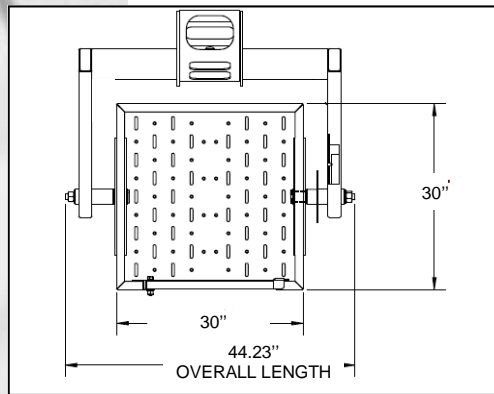
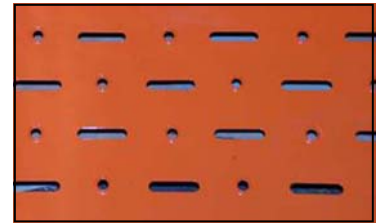

WORK AREA

- Large open area for increased productivity
- Full-sized floor provides more space for men and materials
- 30" x 30"

Features and Benefits:

- Steel construction to meet the rigors of contractors and utility applications
- Fabricated with laser produced parts, keyed together, then welded into place by certified welders
- Entire assembly designed utilizing solid modeling and Finite Element Analysis
- Meets or exceeds industry standards



1001 Webster Avenue
 Waco, Texas 76706
 254-757-1177 phone
 noahg@diversifiedproduct.com
 www.diversifiedproduct.com
 © 2009 Diversified Products

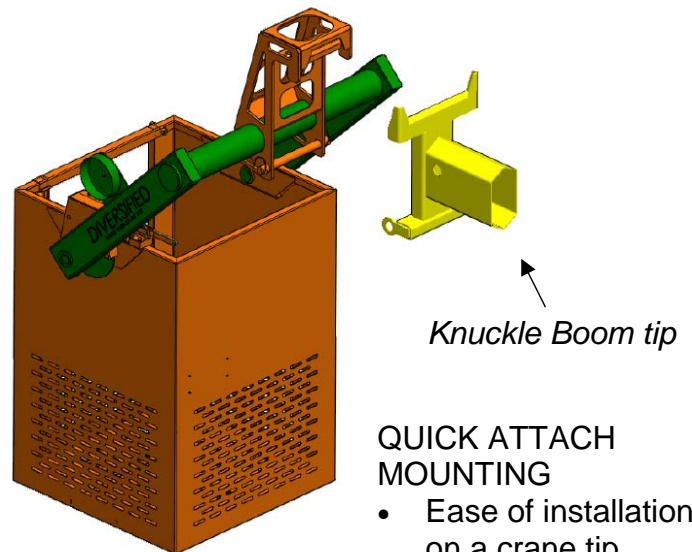

QUICK ATTACH MOUNTING

- Ease of installation on a crane tip
- Basket universal mounting permits installation on multiple cranes

Contact Diversified for all your man basket needs. Yoke style 4', 6', single man, rotating and special requirements.

Diversified Products provides customer-focused solutions to make you more efficient, productive and safe. We manufacture innovative products driven by input straight from the field.

*Photos and diagrams are for promotional purposes only.
 Product design and specifications may change without notice or obligation.*