

AUXILIARY ARM

AA-4-12-1350

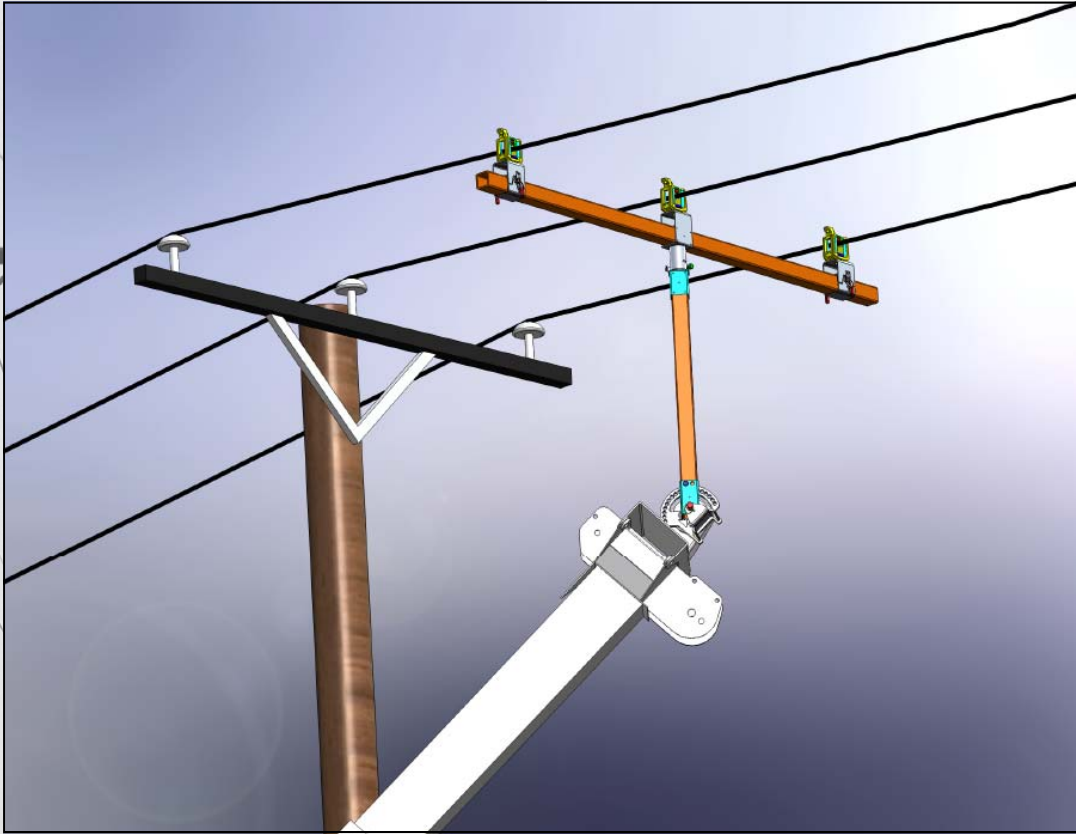

DIVERSIFIED

P R O D U C T S

(254) 757-1177

www.diversifiedproduct.com

The Auxiliary Arm is a practical tool for supporting conductors while replacing insulators, crossarms, poles, hardware and creating working clearance.

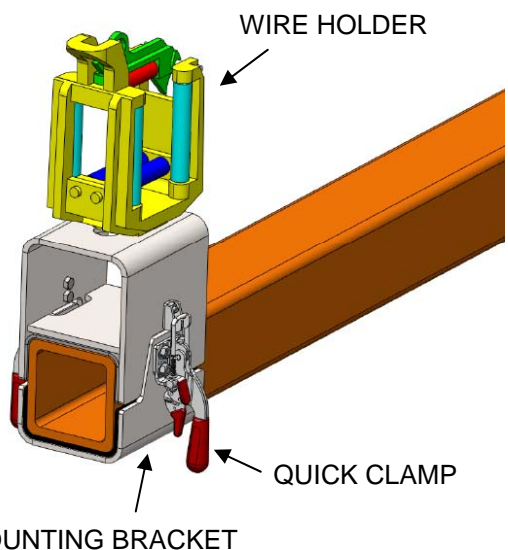
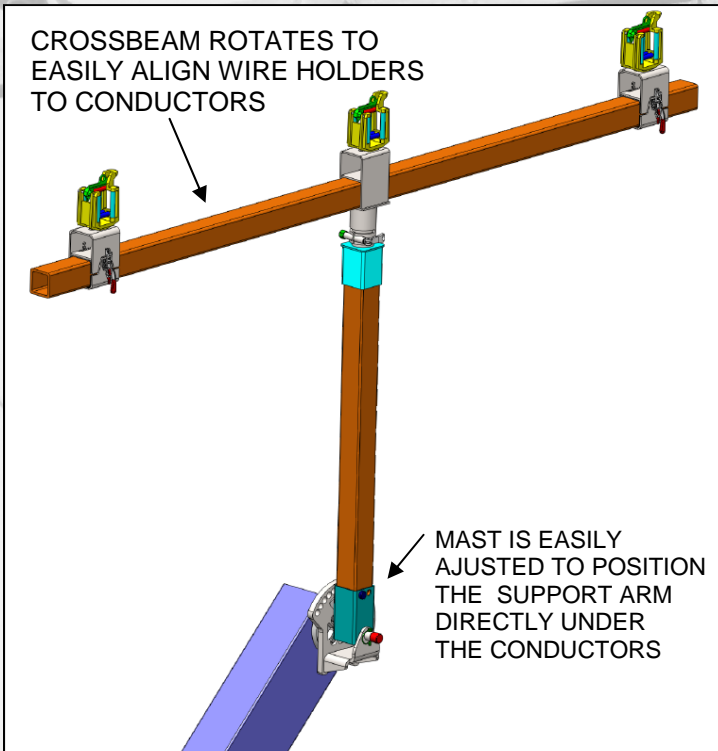

FEATURES AND BENEFITS:

- Wireholder mounting brackets for typical crossarm construction.
- Wireholder bracket for center mast support
- Mounting hardware will fit on crane or derrick boom tip

SPECIFICATIONS (AA-4-12-1350):

- 5' vertical fiberglass mast (4"x 4")
- 12' fiberglass support arm (4"x 4")
- Mechanical Capacity:
 - Balanced Vertical Load: 1,350 lb
 - Unbalanced Vertical Load: 1,000 lb
- Dielectric Capacity: (clear span fiberglass)
 - Mast clear span fiberglass is 4'
 - Arm has 5' clear span fiberglass

OPTIONS:

- Wire holders - Regular duty & Heavy duty
- Neutral wire support
- Storage bags for mast and support arm

MAST WIRE HOLDER BRACKET PERMITS SINGLE-PHASE LIFTS

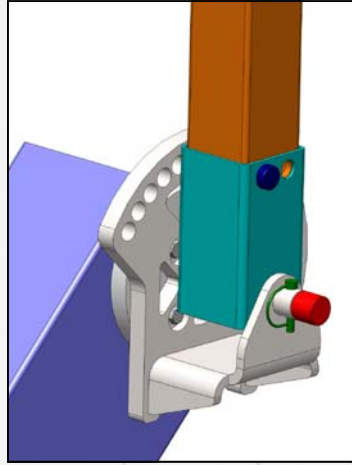
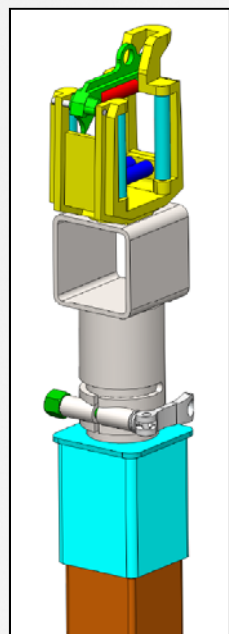

TOOL-LESS MAST INSTALLATION AND ANGLE ADJUSTMENT

Diversified Products provides customer-focused solutions to make you more efficient, productive and safe. We manufacture innovative products driven by input straight from the field. Diversified Products will keep your crew moving down the line.



1001 Webster Avenue
 Waco, Texas 76706
 254-757-1177 phone
 noahg@diversifiedproduct.com
 www.diversifiedproduct.com
 © 2010 Diversified Products

Photos and diagrams are for promotional purposes only. Product design and specifications may change without notice or obligation.